**Implementation of Data Alignment Measures
for the Alignment
of Planning, Lands and Public Works Data**

**Final Report (Volume 2D)
Specification and Explanatory Notes of Road Centreline CSU**

March 2004

Amendment History					
Change Number	Revision Description	Pages Affected on Respective Version	Revision/Version Number	Date	Approval Reference
0	Initial Release		1.0	4 Mar 2004	

Volume 2A - Specification and Explanatory Notes of Slope CSU

Table of Contents

1	Introduction.....	1-1
1.1	General Overview.....	1-1
1.2	Enquires	1-1
2	CSU Definition	2-1
2.1	Overview.....	2-1
2.2	Scope.....	2-2
2.3	Common Rules for Segmentation	2-2
2.4	Common Data Attributes	2-3
2.5	CSU ID.....	2-5
2.6	Data Custodianship.....	2-5
3	CSU Workflow	3-1
3.1	Overview.....	3-1
3.2	Re-alignment, Extension of an Existing Road, or Change in Road Information.....	3-4
3.3	Closing of an Existing Road Centreline CSU	3-5
4	CSU Data Interface Requirement	4-1
4.1	Overview.....	4-1
4.2	CSU Status	4-1
4.3	Themes	4-1
4.4	Logical Data Structure	4-3
4.5	Entity Description.....	4-3
5	Maintenance of the CSU	5-1
5.1	Data Provision Frequency	5-1
5.2	Data Dissemination Frequency.....	5-1
5.3	Mode of Dissemination.....	5-2
Appendix A.	Conventions for Data Interface Requirement.....	A-1

1 Introduction

1.1 General Overview

- 1.1.1 Road Centreline is a standard common spatial unit, comprising spatial data and a set of common attributes, which is defined to facilitate business collaboration that requires exchange of geospatial data of road centreline.
- 1.1.2 This document gives the specification of Road Centreline CSU which shall be followed by all participating departments in the data exchange process. Participating Departments are not obliged to adopt the same specification for their internal systems.
- 1.1.3 The CSU specification includes 4 major components:
- (a) CSU Definition – to describe the scope covered in the CSU, the rules adopted for the segmentation of CSU, the CSU Identifier to uniquely identify a CSU, and the data custodianship;
 - (b) CSU Workflow – to describe the processes and workflows involved in the production and exchange of CSU data during different stages of a CSU lifecycle;
 - (c) CSU Data Interface Requirement – to describe the logical structure of CSU data exchanged between the interfacing systems of PDs;
 - (d) Maintenance of the CSU – to describe the regular mode and frequency of data provision by Data Owner, and dissemination by the Data Agent.

1.2 Enquires

- 1.2.1 Any enquires to the specification shall be referred to the DAM Management Committee, c/o HPLB.

2 CSU Definition

2.1 Overview

2.1.1 Road centreline information is core to the business of the PDs of HPLB and ETWB. RVD, C&SD would require similar information to support their business operation. There are other non PDs who are also key stakeholders in the exchange of road centreline information.

2.1.2 In physical terms, a road is the whole or part of any highway, street, lane, footpath, square or passage. As roads and streets are used interchangeably amongst the PDs, therefore, in this document, the two terms are synonymous. In legal terms, a street in accordance with the Public Health and Municipal Services Ordinance Section 111A is given as follows:-

- (a) A "private street" means a street on land held under Government lease, licence or otherwise from the Government or on land over which the Government has granted or reserved a right of way;
- (b) A "street" includes a private street and any area of land declared to be a street by the Director of Highways Department.

2.1.3 Street name needs to be gazetted by LandsD prior to being adopted for public use. The designated authority for street naming was transferred to LandsD with effect from 27 January 2000. The Survey and Mapping Office (SMO) is responsible for organizing and coordinating the naming of streets and roads and the processing of the gazettement of the names. The arrangement on street naming and process of name gazettement is detailed in SMO QMS document SMWI-TEC-0057 "Street Naming".

2.1.4 When there is a major alignment change due to road planning or redevelopment, the changes would be gazetted. When a street no longer exists due to road works or redevelopment, the deletion of the street name would be gazetted.

2.1.5 Currently, the road centreline maintained in the Street layer of G1000 Library of LandsD is adopted by many government departments and external clients of LandsD. This is a single road centreline system maintained by LandsD and it serves the purpose for geo-referencing, and for PDs to support the operation of their business e.g. PlanD in deriving the planning boundaries and HyD in updating road information.

2.1.6 Transport Department (TD) has recently started the implementation of a Transport Information System (TIS). At the time of preparing this document, they

are yet to confirm their road centreline model. However, it is likely that multiple road centreline system with a complete set of turntables will be developed.

- 2.1.7 Despite the CSU details contained in this document would serve only the 13 PDs, this document would form a good base from which new CSU, when applicable in the business domain of road, could be developed to align the evolving need of the PDs and the non PDs, eg. a new CSU for the multi road centreline.

2.2 Scope

- 2.2.1 A majority of the road network is managed, operated and maintained by HyD. There is a small percentage of the road network maintained by PDs (e.g. WSD, DSD etc) while at the same time, there are some roads maintained by non-PDs (e.g. HA), franchised road operators (e.g. Route 3 Operator) and private developers.
- 2.2.2 The road centrelines form a topologically structured network, which encompasses the territory of Hong Kong. It serves as an index of streets with their geographical locations maintained by LandsD for general mapping purposes.
- 2.2.3 The scope of Road Centreline CSU will include the road centrelines maintained in the Street layer of G1000 (Geographic reference data) library maintained in LandsD's Geographic Information Retrieval System (GIRS).

2.3 Common Rules for Segmentation

- 2.3.1 The Road Centreline CSU, developed from the existing single road centreline system of LandsD, comprises a collection of line segments (roads) and point nodes (road intersections) covering the topological road network of the Hong Kong territory. The existing single road centreline system is currently maintained in the Street layer of LandsD's Basic Mapping System (BMS).
- 2.3.2 The current road centreline is divided into segments at road intersections when two or more roads intersect. The road centreline is also divided at a point node where the street name changes. Under the current provisions of the system, the road segment will be broken when the road segment reaches the tile border, or when the road segment's number of vertices exceeds 500. In such cases, a pseudo node will be added.
- 2.3.3 The single road centreline is created by LandsD either by digitizing a street centreline according to the relevant arcs in the ROAD layer in B1000 library of the Basic Mapping System. The centreline is usually created to run along the mid width of the carriageway, but there is no fixed rule for its exact location.

- 2.3.4 Depending on the geographic spread and extent of the road as identified by its name, one or more than one single road centrelines are attached with the road feature.
- 2.3.5 The single road centreline is made up of a series of arc segments. An arc segment defined by two point nodes forms a topological base for the single road centreline. A point node denotes the start / intersection / junction / end of a road.
- 2.3.6 The current segmentation rules for road centrelines had been built on loose business rules for quite some time and there are situations that these rules are found not adequate for general use. LandsD has recently issued a "Street Centreline Placing Guidelines version 1 (Oct 2003)" on the delineation of road centrelines. It is an objective that these guidelines would give consistent rules to delineating the road centreline in this existing single road centreline system.
- 2.3.7 If there were any odd cases or data issues, they would be brought up to LandsD's attention during maintenance of the Road Centreline CSU. Moreover, LandsD would continue to improve the guidelines to ensure that a consistent definition would be adopted.

2.4 Common Data Attributes

- 2.4.1 The following common attributes are maintained in the Road Centreline CSU dataset for information sharing among PDs:

1. Street Name
2. Street Code
3. Street Type

Table 1 Common data attributes of Road Centreline CSU

- (a) Street Name: the SMO QMS document SMWI-TEC-0057 provides guidelines on the nomenclature of a street, which may be one of the following:-
- (i) Highway e.g. New Territories Circular Road or inter-district distributary road;
 - (ii) Road, Avenue, Drive e.g. district distributary road or Primary road in a layout;
 - (iii) Street e.g. local distributary or secondary road;
 - (iv) Path e.g. pedestrian way;
 - (v) Lane;

- (vi) Terrace e.g. street following a natural feature such as top or face of a slope;
 - (vii) Square e.g. street enclosing large district open space;
 - (viii) Circuit e.g. curved street forming a loop back to its commencing point.
- (b) Street Type: the currently adopted classifications in LandsD will continue to be used within the scope of the Road Centreline CSU. However, LandsD had pointed out that they are not the authority in street classification within the government; such classification is mainly for internal mapping purpose.
- (i) Expressway (EX);
 - (ii) Main road (MA);
 - (iii) Secondary road (SE);
 - (iv) Elevated road, flyover, road bridge (FY);
 - (v) Tunnel (TN);
 - (vi) Non-motorable track (NM);
 - (vii) Closed road (CL);
 - (viii) Restricted access (RA).
- (c) Street Code: Street Code in different pre-defined ranges will be assigned by LandsD to the following:
- (i) Gazetted street – the street authority will gazette a designated street name in both the Chinese and English languages which would then become the official name.
 - (ii) Flyover, tunnel, by-pass and street with ungazetted name – these are streets where the street names have not been gazetted by the street naming authority.
 - (iii) Streets without name – these are streets that have not been allocated a name by the street naming authority.

2.5 CSU ID

2.5.1 The CSU ID comprises the Street Code and a Sub-ID.

- (a) Currently, the Street Code with five digits is used to identify a particular road name designated to the defined road segment(s). These road segments will carry the same Street Code, this identifier, however, cannot uniquely locate and identify each different road segment (between road intersection). The Street Code has 5 digits, in which the first digit of Street Code is used to denote the road nature, for instance, where 'x' denotes a numeric digit:
- (i) 1xxxx - 2xxxx stands for gazetted street;
 - (ii) 3xxxx stands for flyover, tunnel, by-pass and street with un-gazetted name; and
 - (iii) 4xxxx - 5xxxx stands for street without name.
- (b) The Sub-ID is designed to have 3 digits and will be generated by a program automated to uniquely assign the identifier for each road segment having the same Street Code.

2.6 Data Custodianship

2.6.1 Please refer to Volume 2I – Data Custodianship and License Agreement, for the details about defined roles and responsibilities for the Data Agent, Data Owner and Data User.

Data Agent

2.6.2 LandsD is the Data Agent responsible for disseminating CSU data to Data Users.

Data Owner

2.6.3 LandsD is the only Data Owner of Road Centreline CSU.

Data Owner	Attribute Owned
LandsD	1. Street Name
	2. Street Code
	3. Street Type

Data User

- 2.6.4 The Data Users of Road Centreline CSU includes: CED, DSD, HyD, LandsD, PlanD.

3 CSU Workflow

3.1 Overview

3.1.1 The flow charts below are used to describe the data exchange processes among the PDs in the context of Road Centreline CSU. Hence, only those processes that are directly related to update or retrieval on CSU data are indicated. Internal processes within a PD, and data exchange processes between a PD and other organization (e.g. developers, government departments other than the PDs) are not included.

3.1.2 The revised workflow is illustrated by the chart below:

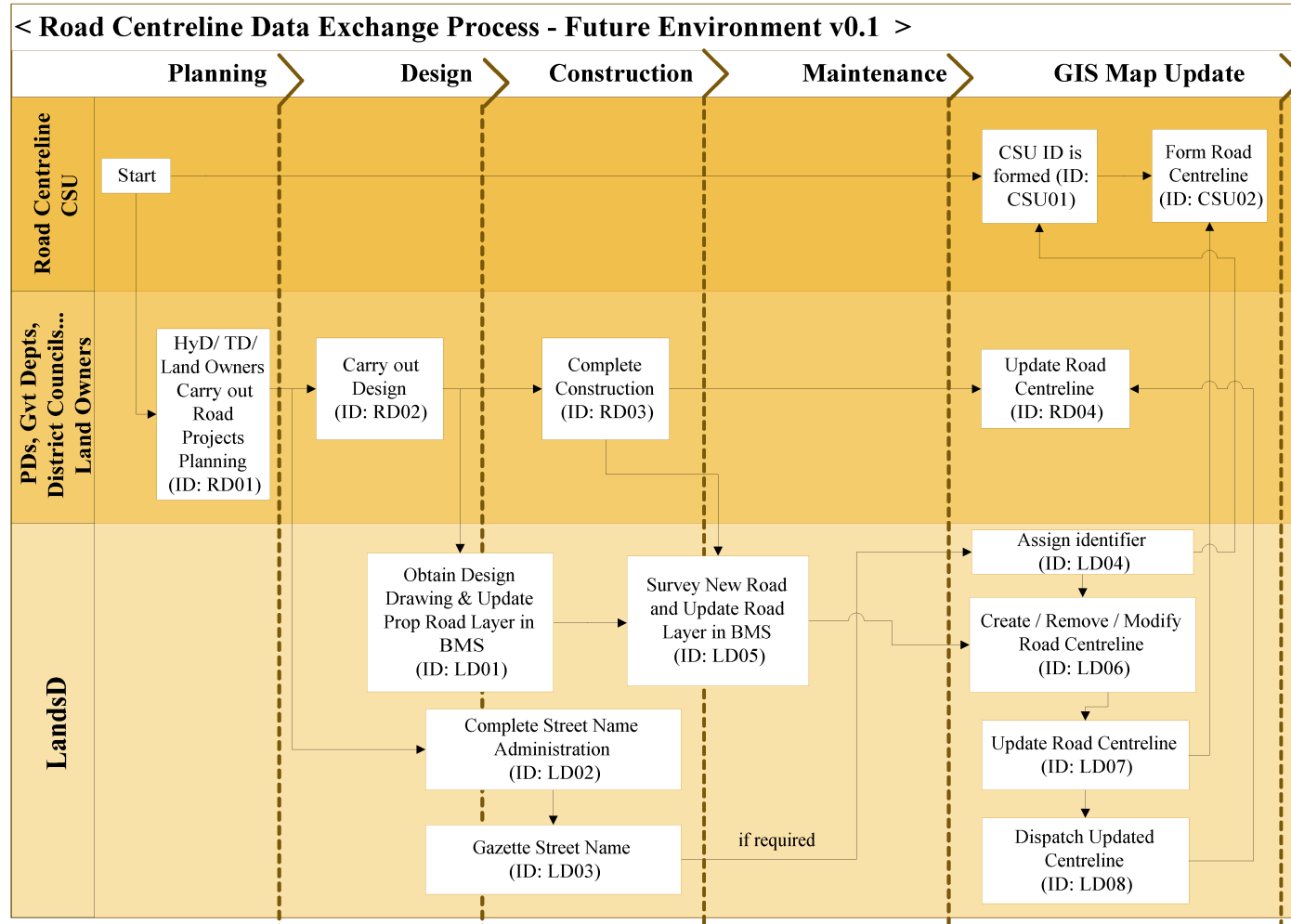

Figure 1 Workflow of Road Centreline CSU

- 3.1.3 The workflow presented in Figure 1 describes the life cycle of the Road Centreline CSU. There are a number of events which will initiate a new or changed road centreline CSU record, including:-
- (a) Construction of a new road;
 - (b) Re-alignment, extension of an existing road, or change in road information;
 - (c) Closing of an existing road.
- 3.1.4 The term “existing” used in this context implies the road already exists as a Road Centreline CSU. Updating of the Road Centreline CSU records will only be required if there are alterations to the attribute and spatial information of a road.

3.2 Data Exchange Processes

Construction of a new road

3.2.1 Planning Stage

- (a) Road developers (HyD, TD, Land owners, etc.) carry out road projects planning which is the beginning stage of a new road (ID: RD01).

3.2.2 Design Stage

- (a) The road design is carried out according to the road projects plan (ID: RD02). The Works departments (and their consultants) who are responsible for the design of new roads, will provide the design drawings in the agreed digital format(s) to LandsD as soon as the design is finalized. LandsD will then update the Proposed Road Layer in the Basic Mapping System accordingly (ID: LD01). (Note: the proposal drawing shall be CSWP compliant. Details will be published by the CSWP Working Group).
- (b) Where the street requires a new name, a request for naming of the new road, with both English and Chinese names, proposed by government departments, district councils, rural committees or land property owners, is submitted to the street naming authority, LandsD (ID: LD02). The procedures and guidelines on the Naming and Gazetting of Street Names in Urban and NT are stipulated in SMO QMS document SMWI-TEC-0057 “Street Naming”.

3.2.3 Construction Stage

- (a) On completion of the new road construction, the road developer(s) will create a temporary road centreline in their data inventory (ID: RD03).
- (b) LandsD will carry out a survey on the newly constructed road and update the Road layer in the BMS (ID: LD05). The Road Centreline CSU for the newly constructed road will be created with a CSU ID, and assigned with the textual attributes (ID: LD06 & LD04).

3.2.4 GIS Map Update

- (a) LandsD will update the Street layer and dispatch the Road Centrelines CSU to other PDs (ID: LD08). HyD, PlanD and other departments will update their departmental systems.

Re-alignment, Extension of an Existing Road, or Change in Road Information

3.2.5 Planning Stage

- (a) In the situations when an un-named street needs to be designated with a new name, an existing street name be designated with another name, or where a road, after removal, no longer exists due to road works or redevelopment, the corresponding new name will be created or deleted by way of a gazette notice (ID: LD02 & LD03). LandsD will modify and update the CSU record accordingly:-
 - (i) In the case when a new street name is assigned to an existing street (gazetted or ungazetted) or to an un-named street, the English Name and Chinese Name of the corresponding Road Name record will be updated.
 - (ii) When an ungazetted street becomes a gazetted street or an un-named street is given a new street name, a new Street Code will need to be assigned to the corresponding Road Name record. Similar changes will be made to the Street Code of the corresponding Road Segment Layer records and the Road Intersection records.
 - (iii) Where a complete road (and associated road segments if applicable) no longer exist(s) after permanent removal, due to road works or redevelopment, the corresponding CSU will be removed, i.e. the corresponding Road Name record, Road Intersection record, Road Segment record and Road Intersection Layer record will be removed accordingly.

3.2.6 GIS Map Update

- (a) Where alterations are made to a road, LandsD will carry out a survey on the modified road and update the road data in BMS (ID: LD05). The Road Centreline CSU will be updated according to the survey data of the modified road (ID: LD06). Road alterations include the following :
 - (i) An extension to an existing road;
 - (ii) Shortening of an existing road; and
 - (iii) A street re-alignment;

- (b) As a result from the road alternation, the geometry of the corresponding arc feature(s) and the node feature(s) in the Road Segment and Road Intersection layers have to be updated accordingly. The relevant textual attributes of the node feature(s), i.e. the data item [Geo.Ref.Number] of the Road Intersection Layer records and the Road Intersection records have to be updated as follow:
 - (i) In case if the street no longer intersects at the original road junctions, then the respective Road Intersection record will be deleted.
 - (ii) In case if the street is now connected to other existing street(s), then new Road Intersection record(s) will need to be created accordingly.

- (c) LandsD will update the Street layer of G1000, prepare the Road Centreline CSU and dispatch the Road Centreline CSU to other PDs (ID: LD07 & LD08). Concerned PDs and other road developer(s) will update their road data inventory on receipt of updated road centreline CSU from LandsD.

Closing of an Existing Road Centreline CSU

- 3.2.7 When a road is removed due to road realignment and redevelopment , the CSU is then deleted.

4 CSU Data Interface Requirement

4.1 Overview

4.1.1 A logical model for CSU data exchange is defined for PDs' exchange of the Road Centreline CSU. It describes the logical structure of CSU data exchanged between the interfacing systems of PDs. PDs, as either Data Owners or Data Users, are not required to adopt the same logical data structure in their own departmental systems. However, each PD is recommended to maintain a mapping between the Common Spatial Units and their departmental records in their respective core departmental systems(s) such that:-

- (a) Data Owner can extract data from her departmental system according to the definition of CSU; and
- (b) Data User can import CSU data into her departmental system for further processing/ analysis.

4.1.2 Mapping of the unique CSU ID with the departmental ID may be a one-to-one, one-to-many or many-to-one relation (but a many-to-many relation is not recommended) depending on the data definition of PDs' departmental records.

4.1.3 For Road Centreline CSU, since some Data Users have already adopted the Street Code in their departmental system, effort required in performing such mapping would be minimal.

4.1.4 The following sections will provide details for the logical model in terms of :-

- (a) CSU status - possible statuses of a CSU;
- (b) Themes - thematic layers; and
- (c) Logical data structure, including a detailed description of the data items and assignment of ownership.

4.2 CSU Status

4.2.1 Since Data Users are not interested in archived data, only the active status of the Road Centreline is required to meet their business needs.

4.3 Themes

4.3.1 The Road Centreline CSU will be organized in two spatial layers:

- (a) Road Segment Layer - It is the linear features representing the active road network;
- (b) Road Intersection Layer - It is the node features representing the active road intersections. The Data User should be noted that given the limitations of existing GIRS, pseudo node will be added when the road segment reaches the tile border, or when the road segment's number of vertices exceeds 500.

4.3.2 The above layers should be confined with HK 1980 Grid Coordinate System, that is the minimum spatial extent and the maximum spatial extent is 800000, 800000 and 867500, 848000 respectively.

4.3.3 It is recommended the full sets of above layers to be maintained in a seamless manner. Thereby, other PDs' post processing effort can be minimized, also, this can facilitate the spatial query and filtering operation.

4.3.4 It is understood that LandsD has an initiative to upgrade their existing CLIS. As a few PDs have already adopted new GIS technology such as object data model in their system, it is recommended that LandsD should revamp the CLIS with priority from Department perspective (i.e. not solely for the Road Centreline CSU) such that its spatial processing capabilities could be in line with the technology trend in the industry, and the data exchange among the PDs and the public could then be improved.

4.4 Logical Data Structure

4.4.1 Please refer to Appendix A for conventions used in this section. The logical relationships among entities are illustrated below.

4.4.2 The logical relationships among entities are illustrated below.

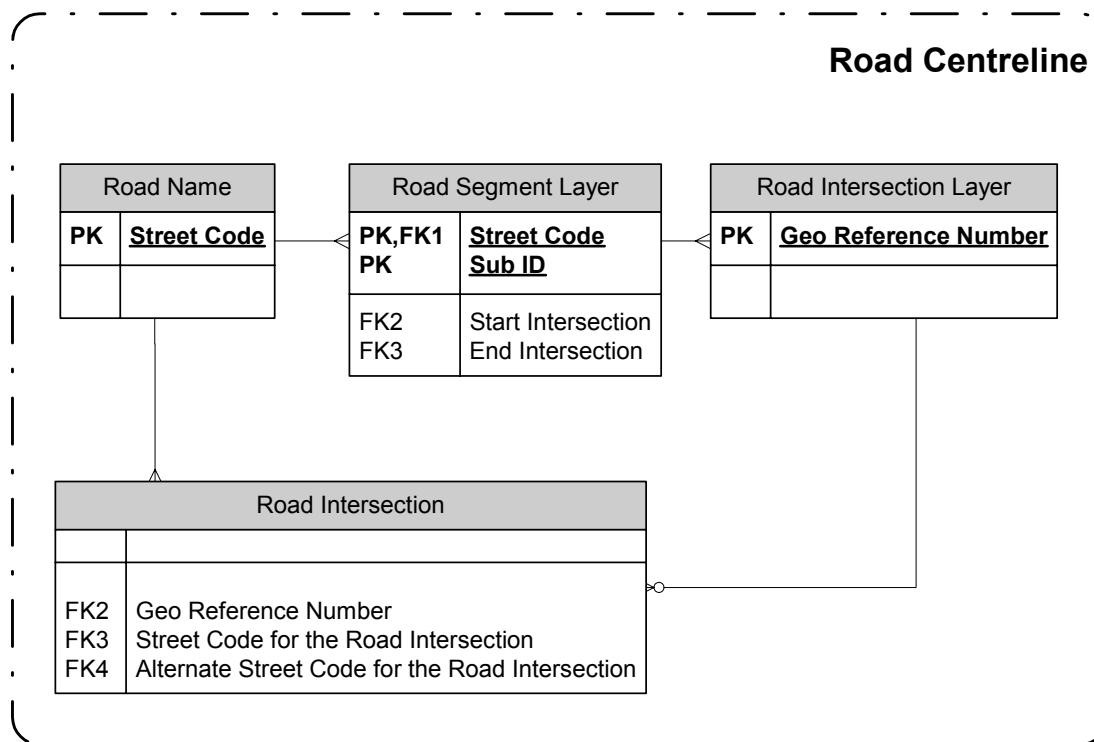

Figure 2 LDS for the Road Centreline CSU

4.5 Entity Description

4.5.1 Some data items may be left as null due to time lag, but must be filled once the CSU is completely defined. Such rules will be described in the Description column of the affected data item. Please also refer to section 3 for more information on the CSU lifecycle.

4.5.2 Some data items are applicable for particular records only. For non-applicable CSUs, such data item(s) are always left as null. For applicable CSUs, such data item(s) is left null for a particular CSU only when the information is not yet available.

4.5.3 Road Segment Layer

- A spatial entity containing the line feature of Road Centreline

(a) Data Item Description

Data Item	Description	Format	Mandatory
Street Code	A unique code number assigned for a particular street name.	N(5)	Y
Sub ID	A number generated automatically by program to denote uniquely each road segment having the same Street Code.	N(3)	Y
Start Intersection	The Start Intersection Node of the Road Segment is defined by the Geo Reference Number stored in the corresponding node. It establishes the link between the Road Segment Layer and the Road Intersection Layer, such that cascade updating can be facilitated even when the arc and node are maintained by two separate spatial layers.	N(10)	Y
End Intersection	The End Intersection Node of the Road Segment, is defined by the Geo Reference Number stored in the corresponding node. It establishes the link between the Road Segment Layer and the Road Intersection Layer, such that cascade updating can be facilitated even when the arc and node are maintained by two separate spatial layers.	N(10)	Y
Geometry	Geometry of line	Line type	Y

Data Item	Description	Format	Mandatory
Street Type	Type of the street for the road segment assigned by LandsD, which consists of eight types: EX = Expressway; MA = Main Road; SE = Secondary Road; FY = Elevated Road, Flyover, Road Bridge; TN = Tunnel; NM = Non-motorable Track; CL = Closed Road; RA = Restricted Access;	X(3)	Y

(b) Constraint Description

Type	Data Item	Validation	Reference Entity	Reference Data Item
PK	Street Code, Sub ID			
CK	Street Code	In ('10001 - 29999' for gazetted street, '30001 - 39999' for flyover, tunnel, by-pass and street with ungazetted name, '40001 - 59999' for street without name)		
CK	Street Type	In ('EX', 'MA', 'SE', 'FY', 'TN', 'NM', 'CL', 'RA')		
FK	Street Code		Street Name	Street Code
FK	Start Intersection		Road Intersection Layer	Geo Reference Number

Type	Data Item	Validation	Reference Entity	Reference Data Item
FK	End Intersection		Road Intersection Layer	Geo Reference Number

(c) Data Ownership

All records	LandsD
-------------	--------

4.5.4 Road Intersection Layer

- A spatial entity containing the node feature of a Road Intersection

(a) Data Item Description

Data Item	Description	Format	Mandatory
Geometry	Geometry of Node	Node type	Y
Geo Reference Number	This is a unique identifier formed by concatenating the Easting (x) and Northing (y) coordinate of the node point. Before concatenation, all decimals of the x-y coordinates are trimmed off and their preceding figures '8' are removed. Thus, the Geo Reference Number of a node of coordinate: '813579.94E; 824680.12N' would become 1357924680. This attribute will be used to link with the Road Intersection entity. For the pseudo nodes that will be added when the arc reaches the tile border or the arc's vertex number is greater than 500, they are required to be assigned a Geo Reference Number as well. Thus, this attribute can form a primary key.	N(10)	Y

(b) Constraint Description

Type	Data Item	Validation	Reference Entity	Reference Data Item
PK	Geo Reference Number			

(c) Data Ownership

All records	LandsD
-------------	--------

4.5.5 Road Intersection

- Information about the street codes at a road intersection. If the node feature represents a cross intersection of more than two roads, more than one entry of Road Intersection record will then be added.

(a) Data Item Description

Data Item	Description	Format	Mandatory
Geo Reference Number	This is an identifier formed by concatenating the Easting (x) and Northing (y) coordinate of the node point. Before concatenation, all decimals of the x-y coordinates are trimmed off and their preceding figures '8' are removed. Thus, the Geo Reference Number of a node of coordinate: '813579.94E; 824680.12N' would become 1357924680. This value is used to map with the Road Intersection layer. For the cross intersection of more than two roads, more than one record with same Geo Reference Number will be resulted. Thus, this attribute cannot become a primary key.	N(10)	Y
Street Code at the Intersection	Street Code at the intersection point	N(5)	Y

Data Item	Description	Format	Mandatory
Alternative Street Code at the Intersection	Alternative Street Code at the intersection point	N(5)	Y

(b) Constraint Description

Type	Data Item	Validation	Reference Entity	Reference Data Item
FK	Geo Reference Number		Road Intersection Layer	Geo Reference Number
FK	Street Code at the Intersection		Road Name	Street Code
FK	Alternative Street Code at the Intersection		Road Name	Street Code

(c) Data Ownership

All records	LandsD
-------------	--------

4.5.6 Road Name

- A textual entity containing the street name of Road Centreline. The Road Segment layer and Road Intersection layer make reference this entity to get the road name.

(a) Data Item Description

Data Item	Description	Format	Mandatory
Street Code	A number assigned by LandsD for a particular street. This is a unique code for street.	N(5)	Y

Data Item	Description	Format	Mandatory
English Street Name	English name of the street.	X(80)	N
Chinese Street Name	Chinese name of the street.	CX(50)	N

(b) Constraint Description

Type	Data Item	Validation	Reference Entity	Reference Data Item
PK	Street Code			

(c) Data Ownership

All records	LandsD
-------------	--------

5 Maintenance of the CSU

5.1 Data Provision Frequency

- 5.1.1 To ensure the time currency of CSU data is maintained to an agreed acceptable level, each Data Owner shall commit to provide their data to the Data Agent at the agreed updating frequency.
- 5.1.2 Data Owners shall provide the latest changes on CSU relevant data to the Data Agent on a regular basis. All changes since the last data upload must be included in the interface data file in the new data upload.
- 5.1.3 LandsD is the only Data Owner contributing data to Road Centreline CSU. The same arrangement will apply to LandsD.
- 5.1.4 The data provision frequency of Road Centreline CSU from LandsD¹ (as Data Owner) is 3 months.

5.2 Data Dissemination Frequency

- 5.2.1 The Data Agent will update the CSU dataset using the latest data provided by the Data Owners. Periodically the Data Agent will pre-pack the CSU data in all the Standard File Formats and make the files available for download by Data Users.
- 5.2.2 Below presents the desirable and minimal tolerable data dissemination frequency for Data Users:

Data User	Required Data Dissemination Frequency	
	Desirable	Lowest Frequency Tolerable
CED	Quarterly	Half-yearly
DSD	Quarterly	Half-yearly
HyD	Monthly	Quarterly

¹ Currently there are several departments have direct connection link to LandsD's CLIS and therefore can get the latest data online (i.e. exchange frequency depends on how frequent the receiving departments download the data from the workstations installed in their own premises).

Direct Access incurs additional costs on communication lines and hardware maintenance. With the implementation of DAM, the Road Centreline CSU will be made available to PDs. To minimize duplication of resource, it is recommended to minimize the Direct Access approach if possible.

Data User	Required Data Dissemination Frequency	
	Desirable	Lowest Frequency Tolerable
PlanD	-	Quarterly

5.2.3 Considering the requirement from various Data Users, the data dissemination frequency of Road Centreline CSU from LandsD (as Data Agent) is 3 months.

5.3 Mode of Dissemination

5.3.1 Upon the implementation of CSU, the Data Users have to acquire the data from the Data Agent, rather than obtaining data from each respective Data Owners, such that the data exchange processes would be streamlined.

5.3.2 To minimize duplicated effort of data dissemination, CSU data shall be disseminated from a single source, i.e. Data Agent. Among the 13 PDs, the current mode of exchange of PLW data will still be retained except those replaced by the exchange of CSU dataset, dissemination of which will be carried out by the data dissemination system provided by each respective the Data Agent.

5.3.3 An automated data dissemination system is recommended for the Road Centreline CSU. A Data Dissemination System (DDS) will be developed and hosted by the Data Agent, i.e. LandsD, who is recommended to handle dissemination of Building CSU, Lot CSU and Road Centreline CSU data.

5.3.4 Subject to finalization of user requirements and selected technical option in the supplementary feasibility study for DDS,

- (a) The system would include a central database, data upload facilities, data import programs, data conversion tools and facilities to allow data download by Data Users. Web-based user interface might be considered as an option for data upload and download facilities.
- (b) Data downloading from Data Agent to Data Users might be supported in both full dataset mode and incremental changes mode by the dissemination system hosted by the Data Agent. Periodically the Data Agent will pre-pack incremental changes in CSU information in all the supported file formats and make the packed files available for download from the dissemination system.
- (c) Data Users can download the incremental changes in their preferred file format at their convenience. Full dataset download will be supported on ad hoc basis. Due to time needed for file format conversion for the large data volume, a full dataset in a requested file format may not be available for download on the fly but only after a couple of days. Meanwhile, all

textual reference code tables will be available in full set mode only and will be refreshed at the same interval as the incremental changes.

Appendix A. Conventions for Data Interface Requirement

A.1.1 Logical Data Structure Diagram

<Entity Name>	
PK	<Data Item 1>
FK1	<Data Item 2>
U1	<Data Item 3>
U1	<Data Item 4>

<Entity Name>	
PK	<Data Item 1>
FK1	<Data Item 2>
U1	<Data Item 3>
U1	<Data Item 4>

Entity

The upper part in grey shading shows the name of the entity.

The lower part lists only the data items involved in the primary key, unique key(s) and foreign key(s) of the entity, while the other data items of the entity will be elaborated in Entity Description.

Composite keys are represented by same key name in multiple data items (e.g. two data items marked as "U1" means a composite unique key composed of two data items)

Mandatory data item(s) will be printed in bold text.

For diagrams spanned across multiple pages, the first occurrence of each entity is shown in solid-line border while all repeated occurrences in later pages are shown in dotted-line border.

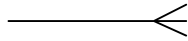

Line with crow's foot

"many" end of a relation



Normal solid line

Mandatory end of a relation

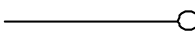

Line with small circle at the end

Optional end of a relation. That is, a record on the left may not have any associated record on the right.

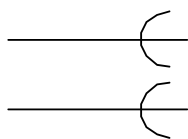

Line with a curve at the end

Exclusive relation. i.e. only 1 among the connected entities on left is linked to the entity on right at a time

A.1.2 Entity Description - Data Item Description - Format

- (a) X(n) : Variable-length character strings of max. length n
- (b) CX(n): Variable-length character strings of maximum n Chinese characters. Maximum number of bytes will depend on the character set used by the CSU dataset. E.g. CX(5) occupies at most 10 bytes if data are stored in Big5 character set.

- (c) N(m,n) : Fixed and floating point numbers, where m is precision (total number of digits before and after decimal point) and n is scale (number of digits to the right of decimal point). The n part is omitted, i.e. denoted in N(m), for integers.
- (d) Date : Point-in-time values (date and time)
- (e) Polygon : Closed polygon representing a spatial area.

A.1.3 Entity Description - Constraint Description - Type

- (a) PK : Data item is part of primary key, which is used to uniquely identify a record in the entity.
- (b) FK : Data item is part of foreign key, which means the data item values, if not null, must match the unique identifier of another entity.
- (c) UK : Data item is part of alternate key, which is used as an alternate way to uniquely identify a record in the entity.
- (d) CK : The value of data item should be checked ensuring that it falls within or meets the predefined values/ranges/rules. Hence, non-mandatory data items can be left as null, or otherwise must meet the criteria.
- (e) CP : The value of geometry type data item should be a closed polygon.

A.1.4 Entity Description - Data Ownership - Condition

- (a) RelatedEntity.DataItem : Reference to value of DataItem of the linked RelatedEntity record. For example, "CSU Feature.Status" means the Status data item of the related CSU Feature record. Unless specified, relation and linked key is determined by the concerned FK constraint as defined in Constraint Description.